

Bills of Material:

NO.	ITEM#	MATERIAL	QTY	UNIT	TOTL WEIGHT	TYPE	ASSY LEVEL
4	303FU-10	Assembly	2			PART	1
3	RAIL	Maple	1			PART	1
2	PULLOUT-ASSY	Assembly	1			ASSEMBLY	1
1	BASE-ASSY	Assembly	1			ASSEMBLY	1

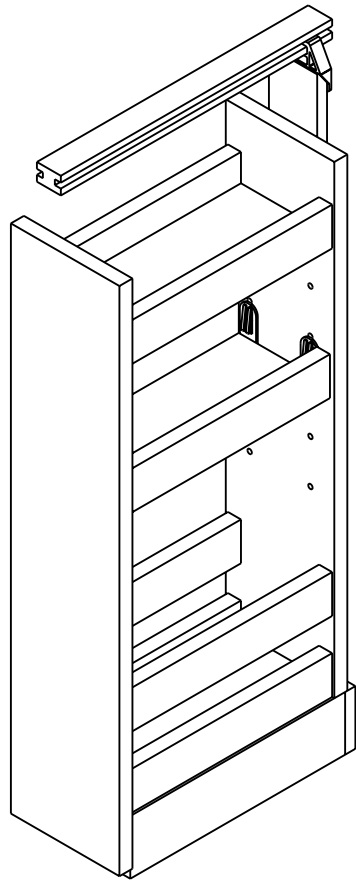

hardware resources	ITEM#: WPO-FAMILY		MATERIAL:		
	FINISH:		WEIGHT: 9		
PROPRIETARY AND CONFIDENTIAL THE INFORMATION CONTAINED IN THIS DRAWING IS THE SOLE PROPERTY OF HARDWARE RESOURCES INC. ANY REPRODUCTION IN PART OR AS A WHOLE WITHOUT THE WRITTEN PERMISSION OF HARDWARE RESOURCES INC. IS PROHIBITED.	TOLERANCE UNLESS OTHERWISE SPECIFIED: X : MM ±0.20 X.X : MM ±0.10 X.XX : MM ±0.05 ANGULAR: ±0.5° DO NOT SCALE DRAWING		UNIT:	DRAWN BY: <i>alan.liu</i>	DATE:
	SIZE:	CHECKED BY:	DATE:		
	APPROVED BY:		DATE:		
	PROJECTION:				

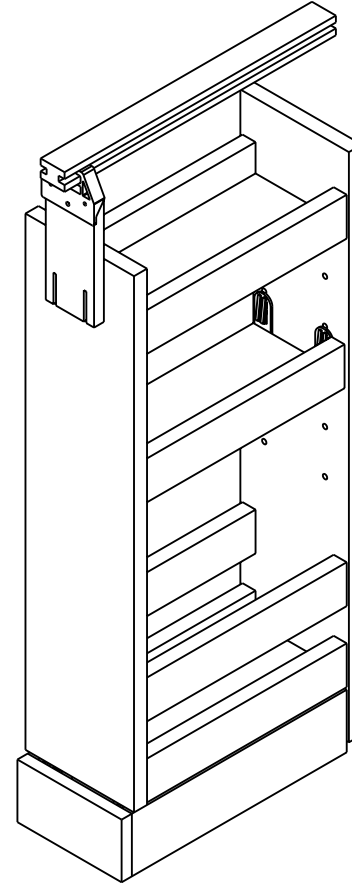

FRONT VIEW



REAR VIEW

	ITEM#: WPO-FAMILY		MATERIAL:	
	FINISH:		WEIGHT: 9	
<p>PROPRIETARY AND CONFIDENTIAL</p> <p>THE INFORMATION CONTAINED IN THIS DRAWING IS THE SOLE PROPERTY OF HARDWARE RESOURCES INC. ANY REPRODUCTION IN PART OR AS A WHOLE WITHOUT THE WRITTEN PERMISSION OF HARDWARE RESOURCES INC. IS PROHIBITED</p>	<p>TOLERANCE UNLESS OTHERWISE SPECIFIED:</p> <p>X : MM ±0.20</p> <p>X.X : MM ±0.10</p> <p>X.XX : MM ±0.05</p> <p>ANGULAR: ±0.5°</p> <p>DO NOT SCALE DRAWING</p>	UNIT:	DRAWN BY:	DATE:
		SIZE:	CHECKED BY:	DATE:
		APPROVED BY:		DATE:
		PROJECTION: 		

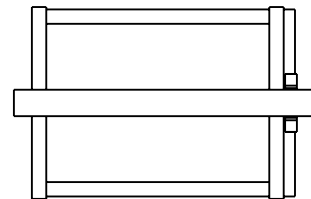
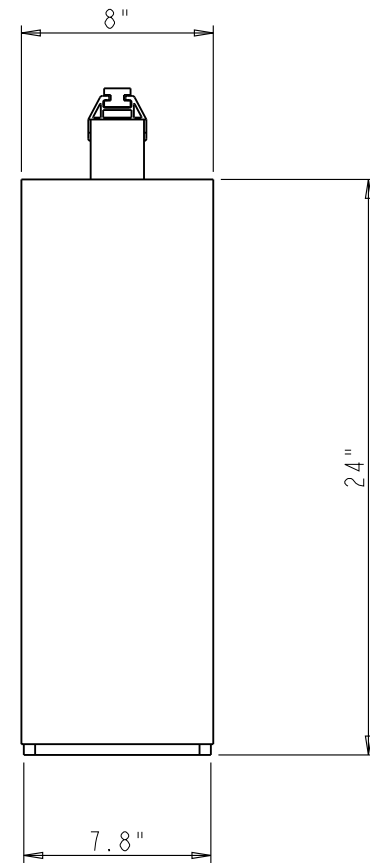
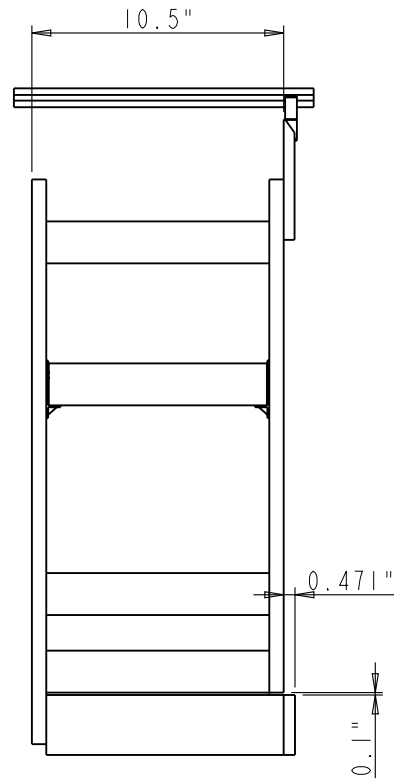

	ITEM#: WPO8		MATERIAL:		
	FINISH:		WEIGHT: 9		
PROPRIETARY AND CONFIDENTIAL THE INFORMATION CONTAINED IN THIS DRAWING IS THE SOLE PROPERTY OF HARDWARE RESOURCES INC. ANY REPRODUCTION IN PART OR AS A WHOLE WITHOUT THE WRITTEN PERMISSION OF HARDWARE RESOURCES INC. IS PROHIBITED.	TOLERANCE UNLESS OTHERWISE SPECIFIED: X: MM ±0.20 X.X: MM ±0.10 X.XX: MM ±0.05 ANGULAR: ±0.5° DO NOT SCALE DRAWING		UNIT:	DRAWN BY: <i>alan.liu</i>	DATE:
	SIZE:	CHECKED BY:	DATE:		
	APPROVED BY:		DATE:		
	PROJECTION:				

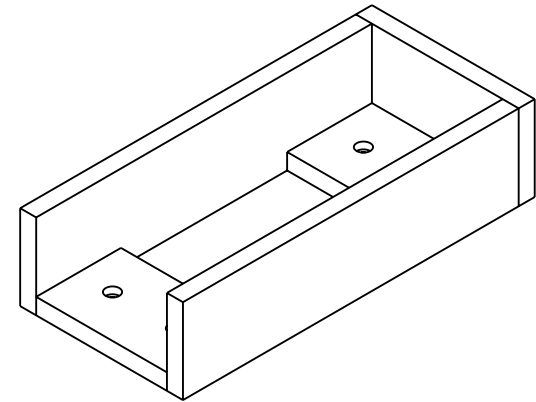
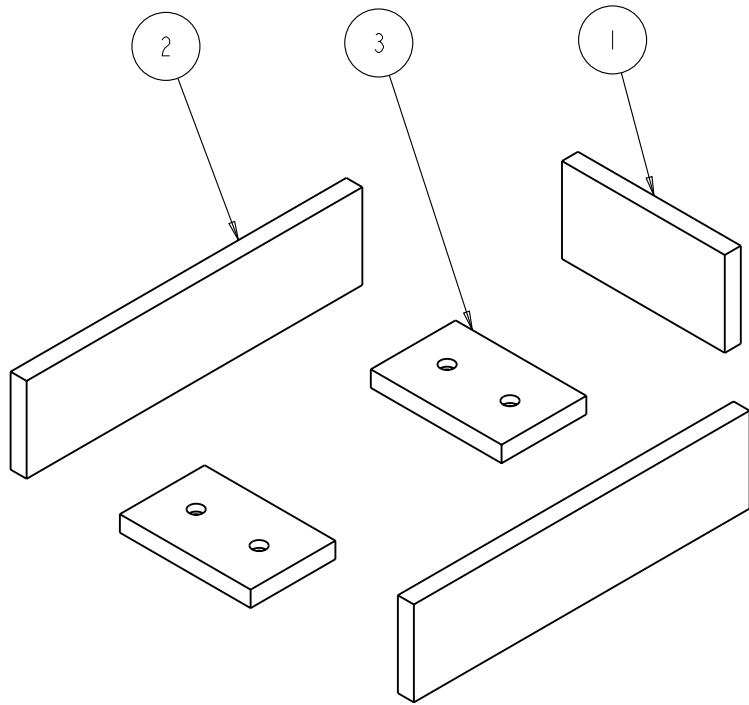

Bills of Material:

NO.	ITEM#	MATERIAL	QTY	UNIT	TOTLE	TYPE	ASSY LEVEL
				WEIGHT			
3	BASE-BOARD-BTM	PLY Wood	2			PART	1
2	SLIDER-MOUNT-BOARD-BASE	PLY Wood	2			PART	1
1	BASE-BOARD-REAR	PLY Wood	1			PART	1

	ITEM#: BASE-ASSY		MATERIAL:		
	FINISH:		WEIGHT: 9		
PROPRIETARY AND CONFIDENTIAL THE INFORMATION CONTAINED IN THIS DRAWING IS THE SOLE PROPERTY OF HARDWARE RESOURCES INC. ANY REPRODUCTION IN PART OR AS A WHOLE WITHOUT THE WRITTEN PERMISSION OF HARDWARE RESOURCES INC. IS PROHIBITED.	TOLERANCE UNLESS OTHERWISE SPECIFIED: X : MM ±0.20 X.X : MM ±0.10 X.XX : MM ±0.05 ANGULAR: ±0.5° DO NOT SCALE DRAWING		UNIT:	DRAWN BY: <i>alan.liu</i>	DATE:
	SIZE:	CHECKED BY:	DATE:		
	APPROVED BY:		DATE:		
	PROJECTION:				

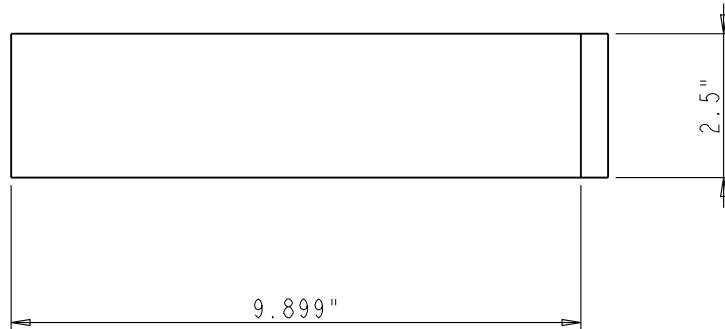
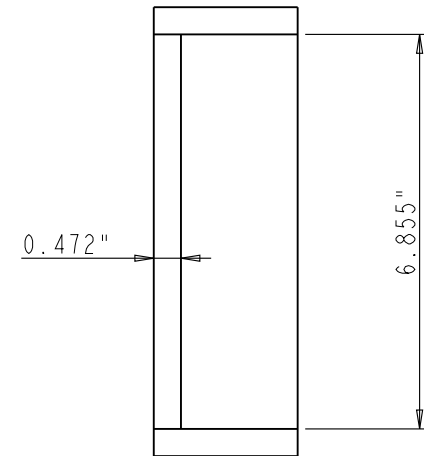
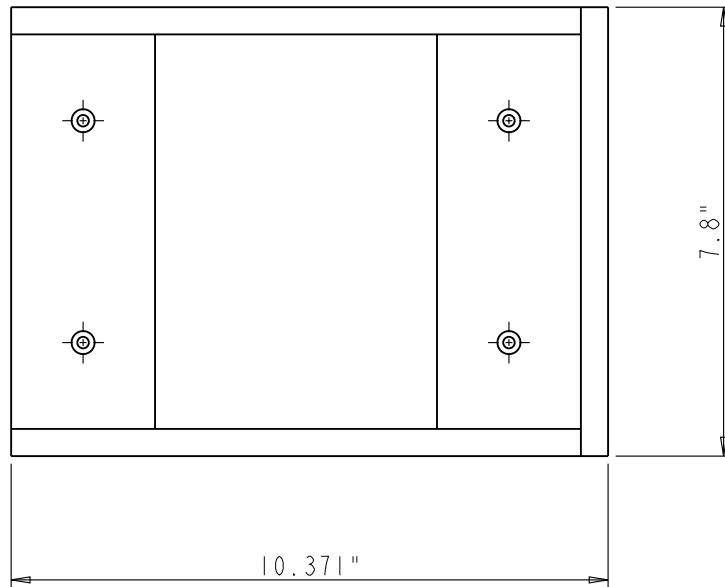

	ITEM#: BASE-ASSY-8		MATERIAL:		
	FINISH:		WEIGHT: 9		
PROPRIETARY AND CONFIDENTIAL THE INFORMATION CONTAINED IN THIS DRAWING IS THE SOLE PROPERTY OF HARDWARE RESOURCES INC. ANY REPRODUCTION IN PART OR AS A WHOLE WITHOUT THE WRITTEN PERMISSION OF HARDWARE RESOURCES INC. IS PROHIBITED.	TOLERANCE UNLESS OTHERWISE SPECIFIED: X : MM ±0.20 X.X : MM ±0.10 X.XX : MM ±0.05 ANGULAR: ±0.5° DO NOT SCALE DRAWING		UNIT: SIZE:	DRAWN BY: <i>alan.liu</i>	DATE:
				CHECKED BY:	DATE:
				APPROVED BY:	DATE:

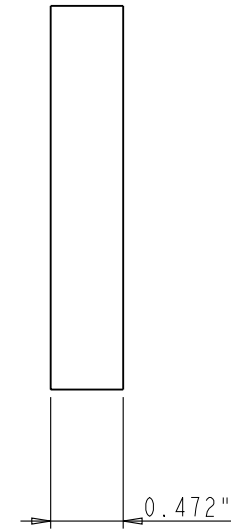
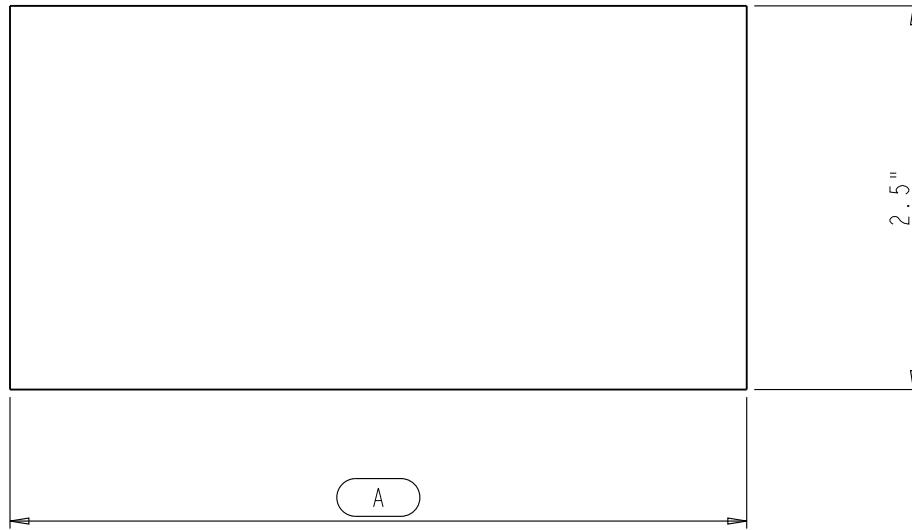

BASE-BOARD-REAR SPEC SHEET:

Part Name	A
BASE-BOARD-REAR-5"	4.8"
BASE-BOARD-REAR-8"	7.8"

NOTE:

The dimension A of current BASE-BOARD-REAR is showing with red frame

	ITEM#: BASE-BOARD-REAR		MATERIAL: PLY Wood		
	FINISH:		WEIGHT: 9		
PROPRIETARY AND CONFIDENTIAL THE INFORMATION CONTAINED IN THIS DRAWING IS THE SOLE PROPERTY OF HARDWARE RESOURCES INC. ANY REPRODUCTION IN PART OR AS A WHOLE WITHOUT THE WRITTEN PERMISSION OF HARDWARE RESOURCES INC. IS PROHIBITED.	TOLERANCE UNLESS OTHERWISE SPECIFIED: X : MM ±0.20 X.X : MM ±0.10 X.XX : MM ±0.05 ANGULAR: ±0.5° DO NOT SCALE DRAWING		UNIT:	DRAWN BY: <i>alan.liu</i>	DATE:
	SIZE:	CHECKED BY:	DATE:		
	APPROVED BY:		DATE:		
	PROJECTION:				

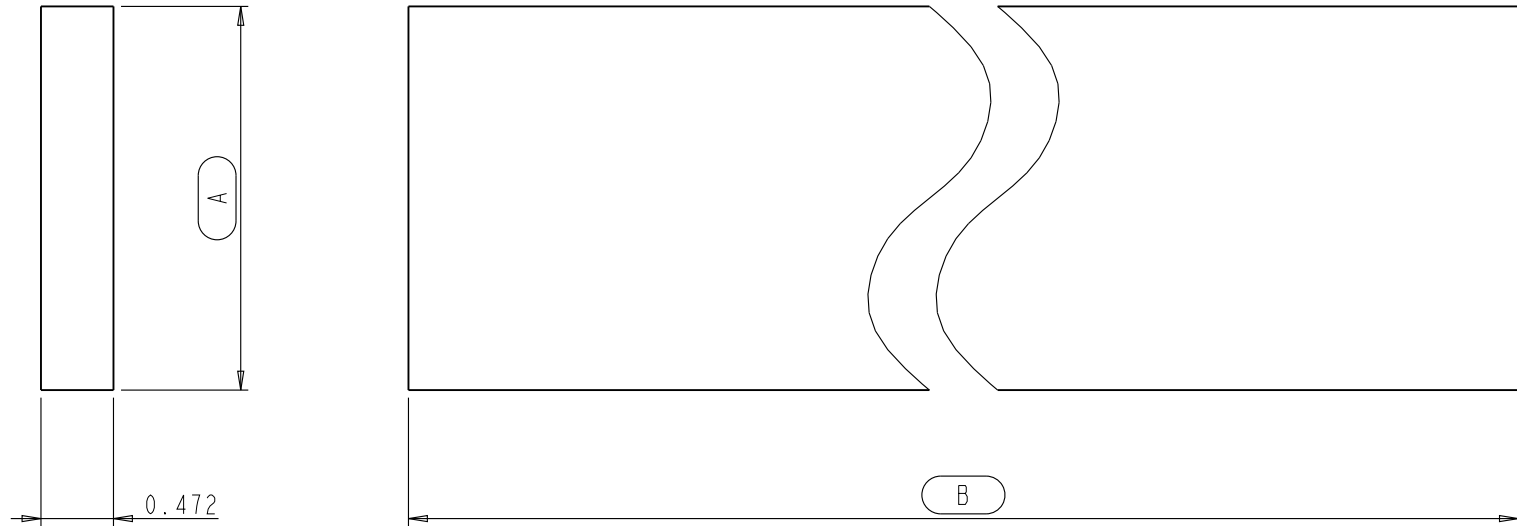

SLIDER-MOUNT-BOARD SPEC SHEET:

Part Name	A	B
SLIDER-MOUNT-BOARD-BASE	2.5"	9.899"
SLIDER-MOUNT-BOARD-PULLOUT	2.3"	9.3"

NOTE:

The dimension A & B of current SLIDER-MOUNT-BOARD is showing with red frame

	ITEM: SLIDER-MOUNT-BOARD		MATERIAL: PLY Wood		
	FINISH:		WEIGHT: 9		
PROPRIETARY AND CONFIDENTIAL THE INFORMATION CONTAINED IN THIS DRAWING IS THE SOLE PROPERTY OF HARDWARE RESOURCES INC. ANY REPRODUCTION IN PART OR AS A WHOLE WITHOUT THE WRITTEN PERMISSION OF HARDWARE RESOURCES INC. IS PROHIBITED	TOLERANCE UNLESS OTHERWISE SPECIFIED: X : MM ±0.20 X.X : MM ±0.10 X.XX : MM ±0.05 ANGULAR: ±0.5° DO NOT SCALE DRAWING		UNIT: SIZE:	DRAWN BY: <i>alan.liu</i>	DATE:
			CHECKED BY:	DATE:	
			APPROVED BY:	DATE:	
			PROJECTION:		

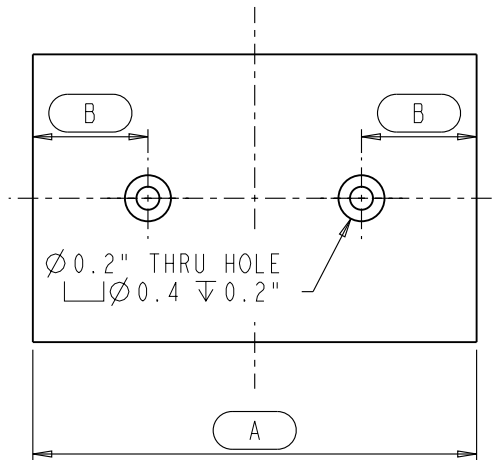

BASE-BOARD-BTM SPEC SHEET:

Part Name	A	B
BASE-BOARD-BTM-5	3.855"	1"
BASE-BOARD-BTM-8	6.855"	1.5"

NOTE:

The dimension A & B of current BASE-BOARD-BTM is showing with red frame

	ITEM: BASE-BOARD-BTM		MATERIAL: PLY Wood		
	FINISH:		WEIGHT: 9		
PROPRIETARY AND CONFIDENTIAL THE INFORMATION CONTAINED IN THIS DRAWING IS THE SOLE PROPERTY OF HARDWARE RESOURCES INC. ANY REPRODUCTION IN PART OR AS A WHOLE WITHOUT THE WRITTEN PERMISSION OF HARDWARE RESOURCES INC. IS PROHIBITED	TOLERANCE UNLESS OTHERWISE SPECIFIED: X : MM ±0.20 X.X : MM ±0.10 X.XX : MM ±0.05 ANGULAR: ±0.5° DO NOT SCALE DRAWING		UNIT:	DRAWN BY: <i>alan.liu</i>	DATE:
	SIZE:	CHECKED BY:	DATE:		
	APPROVED BY:		DATE:		
	PROJECTION:				

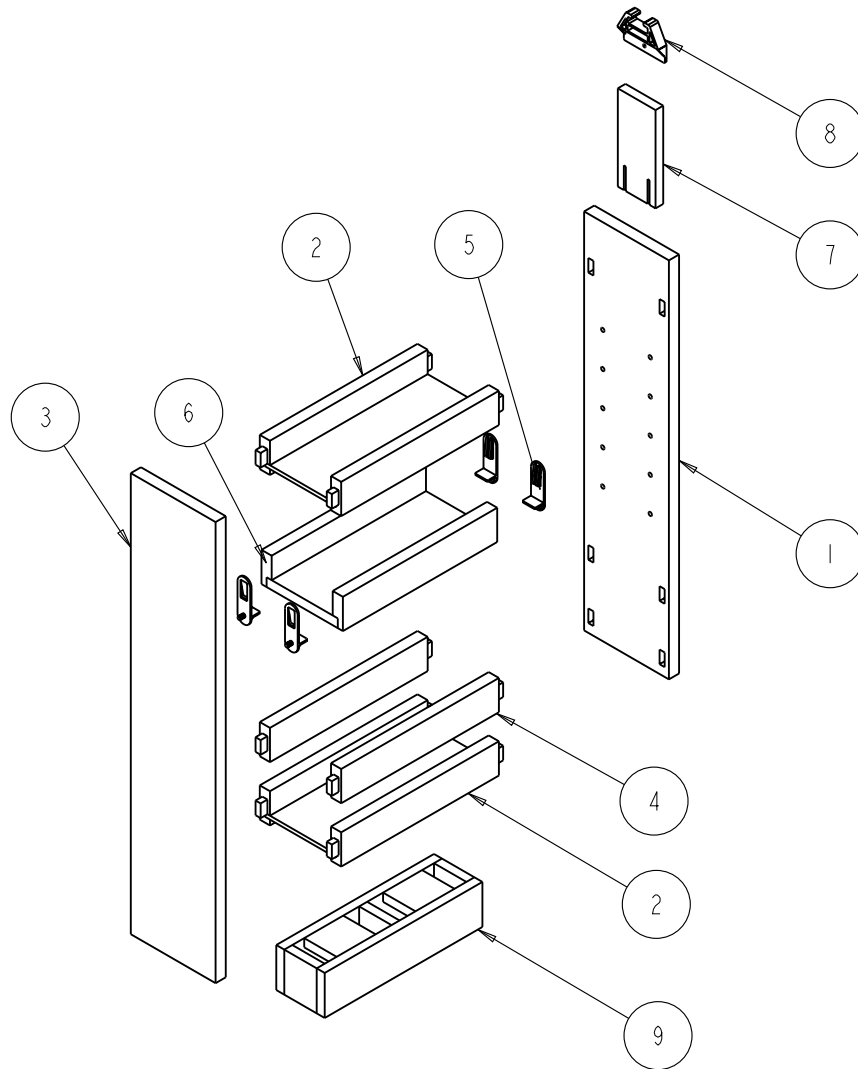

Bills of Material:

NO.	ITEM#	MATERIAL	QTY	UNIT	TOTLE WEIGHT	TYPE	ASSY LEVEL
9	BOTTOM	Assembly	1			ASSEMBLY	1
8	HOLDER	ABS	1			PART	1
7	HOLDER-MOUNT	PLY Wood	1			PART	1
6	SHELF-ADJUSTABLE	Assembly	1			ASSEMBLY	1
5	7704	SAN	4			PART	1
4	SIDE-BOARD-SUPPORT	PLY Wood	2			PART	1
3	FACADE-BOARD-FRONT	PLY Wood	1			PART	1
2	SHELF-FIXED	Assembly	2			ASSEMBLY	1
1	FACADE-BOARD-REAR	PLY Wood	1			PART	1

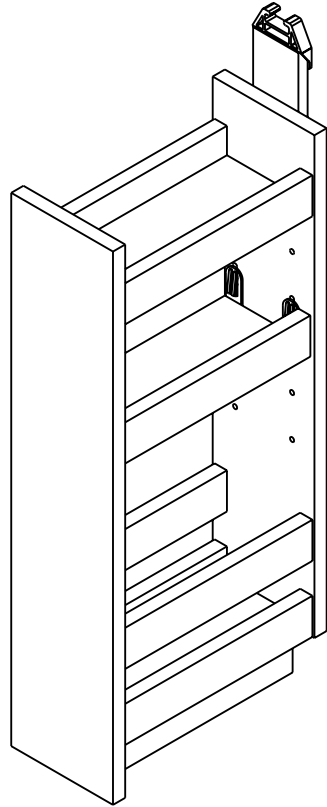

	ITEM#: PULLOUT-ASSY		MATERIAL:		
	FINISH:		WEIGHT: 9		
PROPRIETARY AND CONFIDENTIAL THE INFORMATION CONTAINED IN THIS DRAWING IS THE SOLE PROPERTY OF HARDWARE RESOURCES INC. ANY REPRODUCTION IN PART OR AS A WHOLE WITHOUT THE WRITTEN PERMISSION OF HARDWARE RESOURCES INC. IS PROHIBITED.	TOLERANCE UNLESS OTHERWISE SPECIFIED: X: MM ±0.20 X.X: MM ±0.10 X.XX: MM ±0.05 ANGULAR: ±0.5° DO NOT SCALE DRAWING		UNIT:	DRAWN BY: <i>alan.liu</i>	DATE:
	SIZE:	CHECKED BY:	DATE:		
	APPROVED BY:		DATE:		
	PROJECTION:				

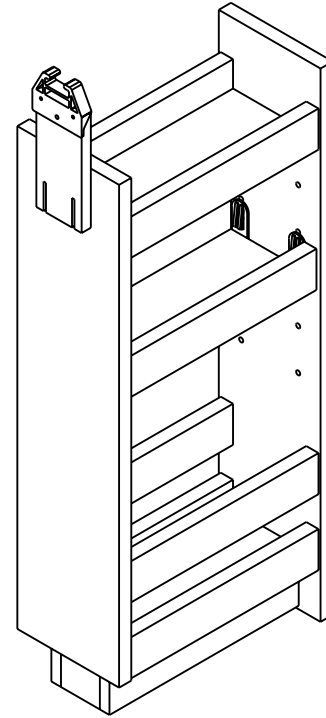

FRONT VIEW



REAR VIEW

	ITEM: PULLOUT-ASSY		MATERIAL:	
	FINISH:		WEIGHT: 9	
<p>PROPRIETARY AND CONFIDENTIAL</p> <p>THE INFORMATION CONTAINED IN THIS DRAWING IS THE SOLE PROPERTY OF HARDWARE RESOURCES INC. ANY REPRODUCTION IN PART OR AS A WHOLE WITHOUT THE WRITTEN PERMISSION OF HARDWARE RESOURCES INC. IS PROHIBITED</p>	<p>TOLERANCE UNLESS OTHERWISE SPECIFIED:</p> <p>X : MM ±0.20</p> <p>X.X : MM ±0.10</p> <p>X.XX : MM ±0.05</p> <p>ANGULAR: ±0.5°</p> <p>DO NOT SCALE DRAWING</p>	UNIT:	DRAWN BY: <i>alan.liu</i>	DATE:
		SIZE:	CHECKED BY:	DATE:
		APPROVED BY:		DATE:
		PROJECTION: 		

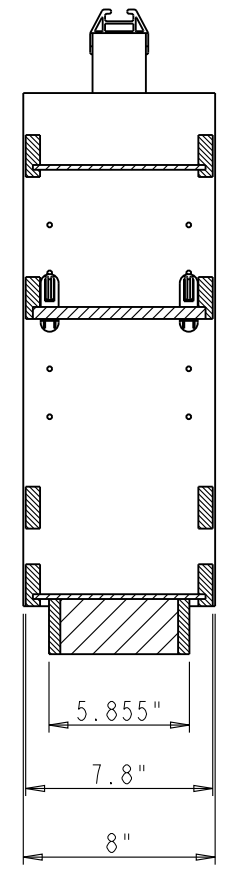
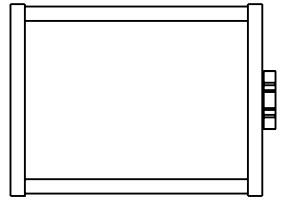
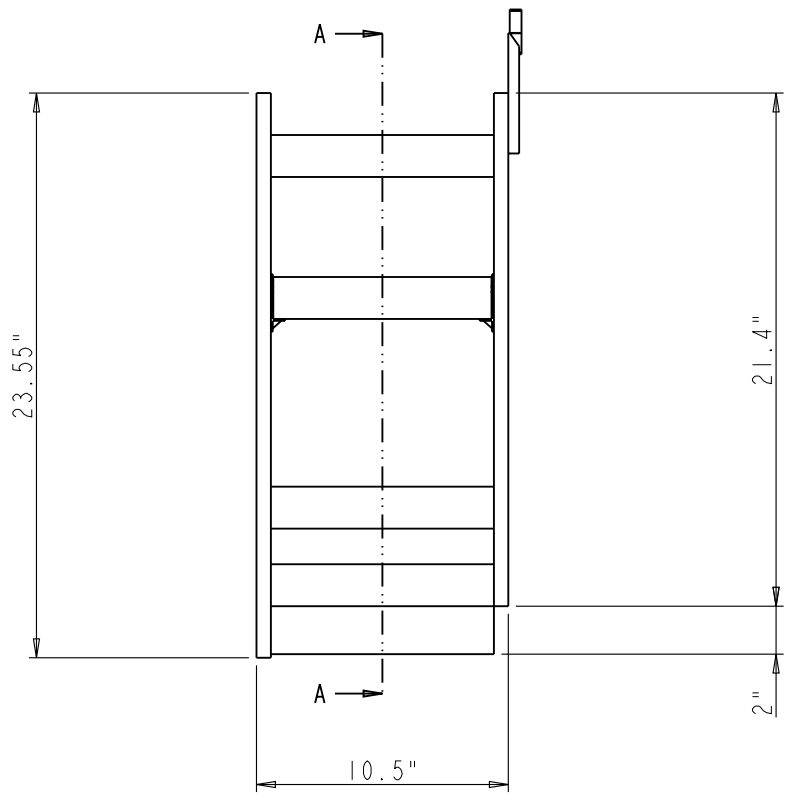

SECTION A-A

	ITEM: PULLOUT-ASSY-8		MATERIAL:		
	FINISH:		WEIGHT: 9		
PROPRIETARY AND CONFIDENTIAL THE INFORMATION CONTAINED IN THIS DRAWING IS THE SOLE PROPERTY OF HARDWARE RESOURCES INC. ANY REPRODUCTION IN PART OR AS A WHOLE WITHOUT THE WRITTEN PERMISSION OF HARDWARE RESOURCES INC. IS PROHIBITED.	TOLERANCE UNLESS OTHERWISE SPECIFIED: X : MM ±0.20 XX : MM ±0.10 XXX : MM ±0.05 ANGULAR: ±0.5° DO NOT SCALE DRAWING		UNIT:	DRAWN BY: <i>alan.liu</i>	DATE:
	SIZE:	CHECKED BY:	DATE:		
	APPROVED BY:		DATE:		
	PROJECTION:				

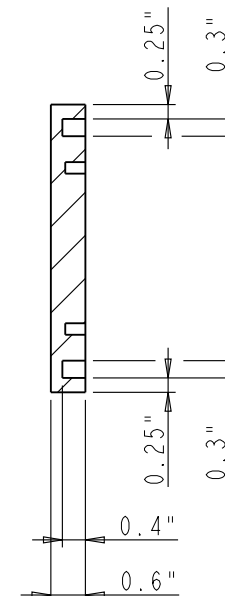
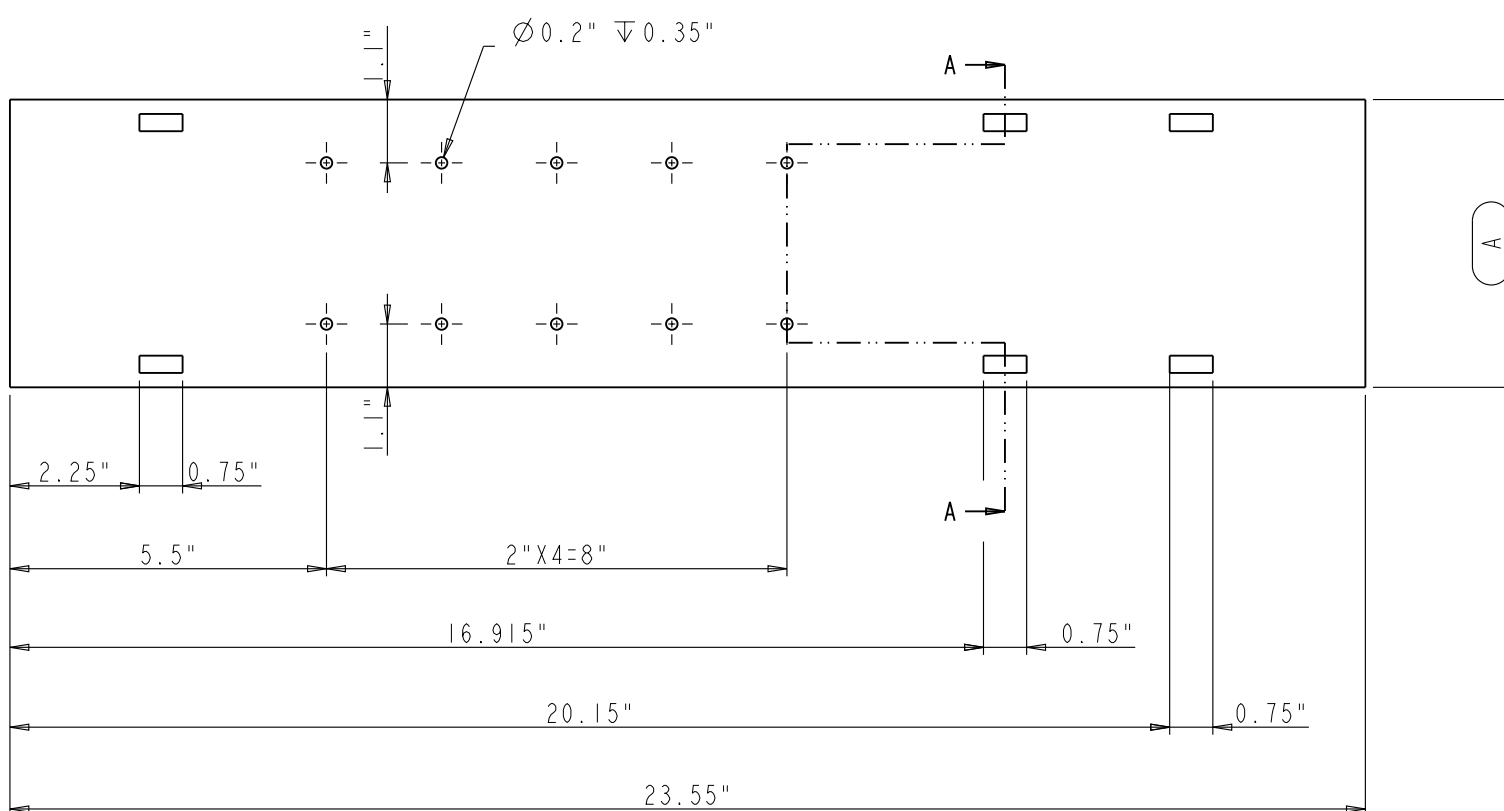

SECTION A-A

FACADE-BOARD-FRONT SPEC SHEET:

Part Name	A
FACADE-BOARD-FRONT-5	5"
FACADE-BOARD-FRONT-8	8"

NOTE:

The dimension A of current FACADE-BOARD-FRONT is showing with red frame

	ITEM: FACADE-BOARD-FRONT		MATERIAL: PLY Wood		
	FINISH:		WEIGHT: 9		
PROPRIETARY AND CONFIDENTIAL THE INFORMATION CONTAINED IN THIS DRAWING IS THE SOLE PROPERTY OF HARDWARE RESOURCES INC. ANY REPRODUCTION IN PART OR AS A WHOLE WITHOUT THE WRITTEN PERMISSION OF HARDWARE RESOURCES INC. IS PROHIBITED.	TOLERANCE UNLESS OTHERWISE SPECIFIED: X: MM ±0.20 X.X: MM ±0.10 X.XX: MM ±0.05 ANGULAR: ±0.5° DO NOT SCALE DRAWING		UNIT:	DRAWN BY: <i>alan.liu</i>	DATE:
	SIZE:	CHECKED BY:	DATE:		
	APPROVED BY:		DATE:		
	PROJECTION:				

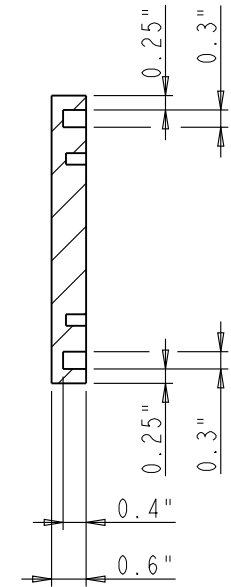
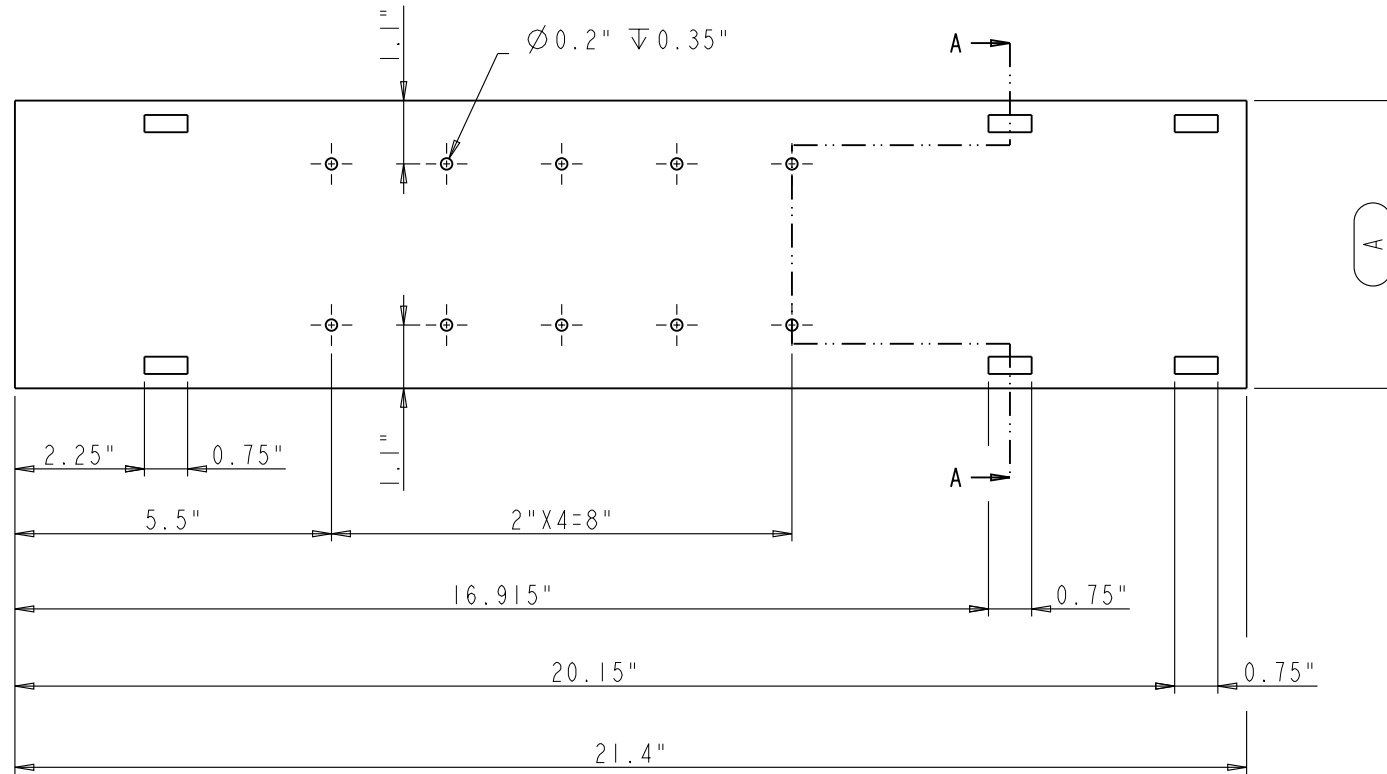

SECTION A-A

FACADE-BOARD-REAR SPEC SHEET:

Part Name	A
FACADE-BOARD-REAR-5	5"
FACADE-BOARD-REAR-8	8"

NOTE:

The dimension A of current BASE-BOARD-BTM is showing with red frame

hardware resources	ITEM: FACADE-BOARD-REAR		MATERIAL: PLY Wood		
	FINISH:		WEIGHT: 9		
PROPRIETARY AND CONFIDENTIAL THE INFORMATION CONTAINED IN THIS DRAWING IS THE SOLE PROPERTY OF HARDWARE RESOURCES INC. ANY REPRODUCTION IN PART OR AS A WHOLE WITHOUT THE WRITTEN PERMISSION OF HARDWARE RESOURCES INC. IS PROHIBITED	TOLERANCE UNLESS OTHERWISE SPECIFIED: X: MM ±0.20 XX: MM ±0.10 XXX: MM ±0.05 ANGULAR: ±0.5° DO NOT SCALE DRAWING		UNIT:	DRAWN BY: <i>alan.liu</i>	DATE:
	SIZE:	CHECKED BY:	DATE:		
	APPROVED BY:		DATE:		
	PROJECTION:				

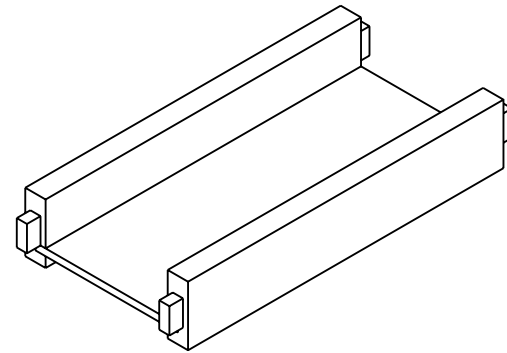
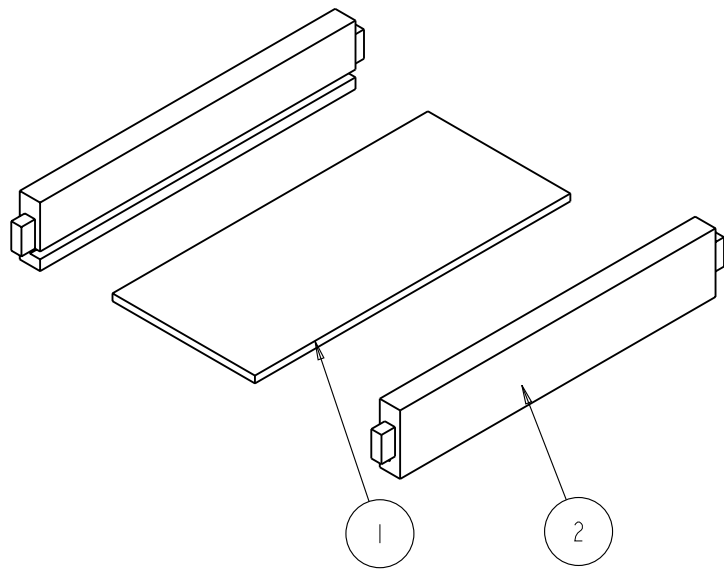

Bills of Material:

2	SIDE-BOARD-FIXED-SHELF	PLY Wood	2			PART	1
1	SHELF-BOARD-FIXED	PLY Wood	1			PART	1
NO.	ITEM#	MATERIAL	QTY	UNIT	TOTLE	TYPE	ASSY LEVEL
				WEIGHT			
		ITEM#: SHELF-FIXED			MATERIAL:		
PROPRIETARY AND CONFIDENTIAL THE INFORMATION CONTAINED IN THIS DRAWING IS THE SOLE PROPERTY OF HARDWARE RESOURCES INC. ANY REPRODUCTION IN PART OR AS A WHOLE WITHOUT THE WRITTEN PERMISSION OF HARDWARE RESOURCES INC. IS PROHIBITED.		FINISH:			WEIGHT: 9		
TOLERANCE UNLESS OTHERWISE SPECIFIED: X: MM ±0.20 X.X: MM ±0.10 X.XX: MM ±0.05 ANGULAR: ±0.5° DO NOT SCALE DRAWING		UNIT:	DRAWN BY: <i>alan.liu</i>		DATE:		
		SIZE:	CHECKED BY:		DATE:		
		PAGE 00		APPROVED BY:		DATE:	

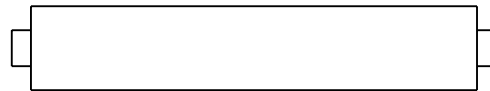
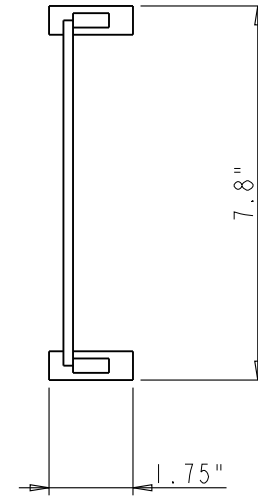
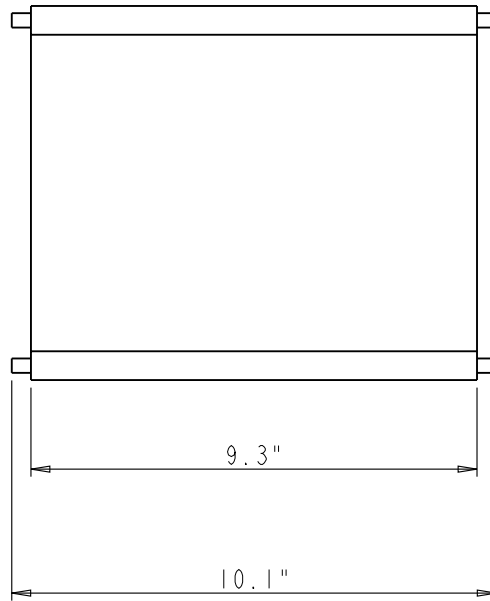

	ITEM#: SHELF-FIXED-8		MATERIAL:		
	FINISH:		WEIGHT: 9		
PROPRIETARY AND CONFIDENTIAL THE INFORMATION CONTAINED IN THIS DRAWING IS THE SOLE PROPERTY OF HARDWARE RESOURCES INC. ANY REPRODUCTION IN PART OR AS A WHOLE WITHOUT THE WRITTEN PERMISSION OF HARDWARE RESOURCES INC. IS PROHIBITED.	TOLERANCE UNLESS OTHERWISE SPECIFIED: X : MM ±0.20 X.X : MM ±0.10 X.XX : MM ±0.05 ANGULAR: ±0.5° DO NOT SCALE DRAWING		UNIT: SIZE:	DRAWN BY: <i>alan.liu</i>	DATE:
				CHECKED BY:	DATE:
				APPROVED BY:	DATE:

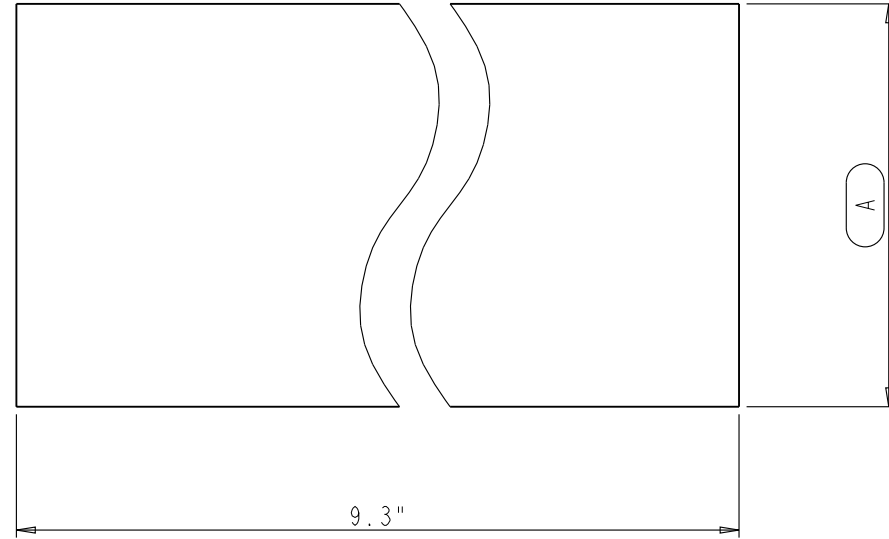
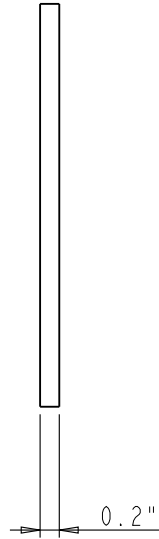

SHELF-BOARD-FIXED SPEC SHEET:



Part Name	A
SHELF-BOARD-FIXED-5	4.2"
SHELF-BOARD-FIXED-8	7.2"

NOTE:

The dimension A of current SHELF-BOARD-FIXED is showing with red frame

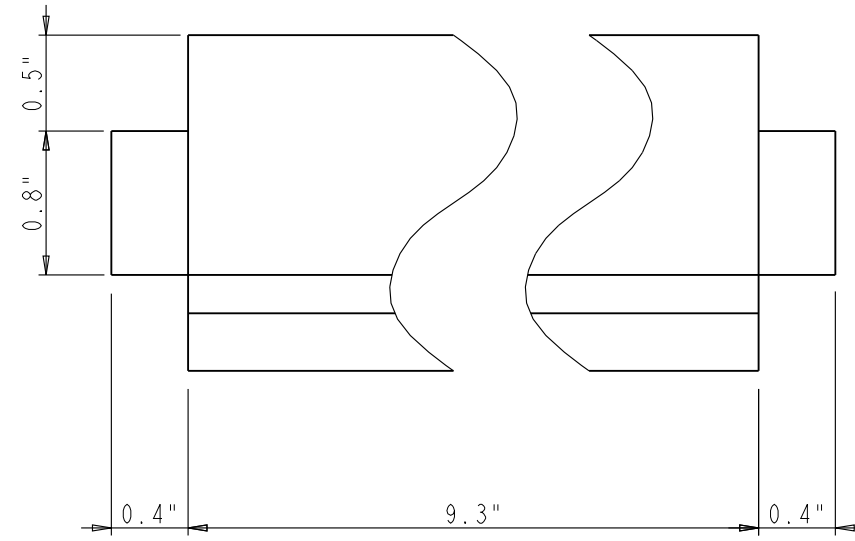
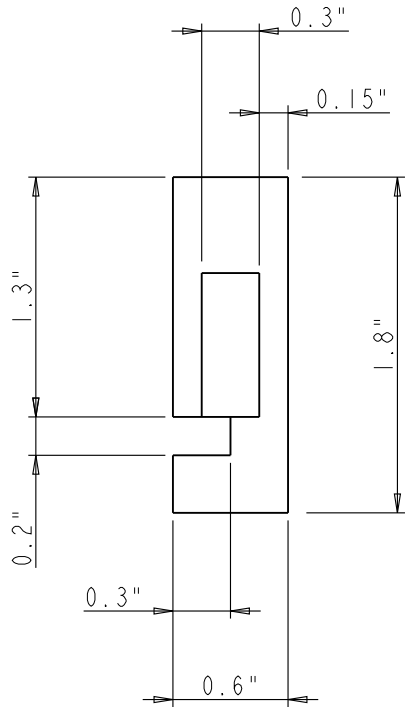

	ITEM#: SHELF-BOARD-FIXED		MATERIAL: PLY Wood		
	FINISH:		WEIGHT: 9		
PROPRIETARY AND CONFIDENTIAL THE INFORMATION CONTAINED IN THIS DRAWING IS THE SOLE PROPERTY OF HARDWARE RESOURCES INC. ANY REPRODUCTION IN PART OR AS A WHOLE WITHOUT THE WRITTEN PERMISSION OF HARDWARE RESOURCES INC. IS PROHIBITED	TOLERANCE UNLESS OTHERWISE SPECIFIED: X : MM ±0.20 X.X : MM ±0.10 X.XX : MM ±0.05 ANGULAR: ±0.5° DO NOT SCALE DRAWING		UNIT:	DRAWN BY: <i>alan.liu</i>	DATE:
	SIZE:	CHECKED BY:	DATE:		
	APPROVED BY:		DATE:		
	PROJECTION:				

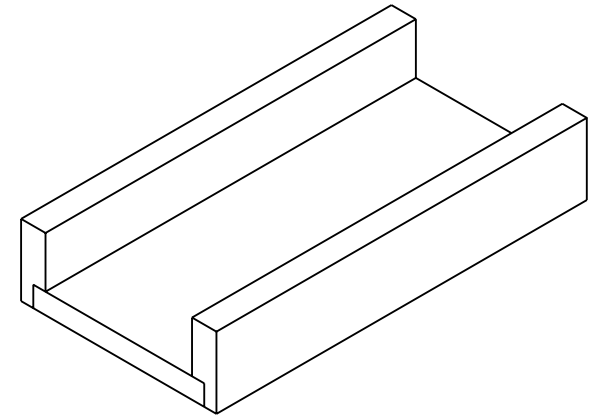
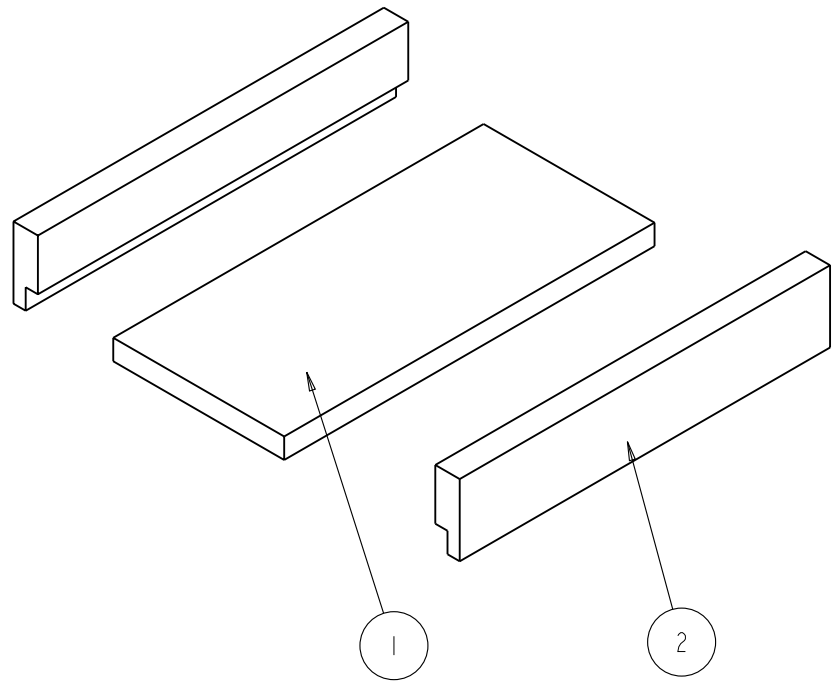

	ITEM#: SIDE-BOARD-FIXED-SHELF		MATERIAL: PLY Wood	
	FINISH:		WEIGHT: 9	
<p>PROPRIETARY AND CONFIDENTIAL</p> <p>THE INFORMATION CONTAINED IN THIS DRAWING IS THE SOLE PROPERTY OF HARDWARE RESOURCES INC. ANY REPRODUCTION IN PART OR AS A WHOLE WITHOUT THE WRITTEN PERMISSION OF HARDWARE RESOURCES INC. IS PROHIBITED</p>	TOLERANCE UNLESS OTHERWISE SPECIFIED:		PROJECTION: 	
	X : MM ±0.20	UNIT:	DRAWN BY: <i>alan.liu</i>	
	X.X : MM ±0.10	SIZE:	CHECKED BY:	
	X.XX : MM ±0.05		APPROVED BY:	
ANGULAR: ±0.5°		DATE:		
DO NOT SCALE DRAWING		DATE:		



Bills of Material:

2	SIDE-BOARD-ADJUSTABLE-SHELF	PLY Wood	2			PART	1
1	SHELF-BOARD-ADJUSTABLE	PLY Wood	1			PART	1
NO.	ITEM#	MATERIAL	QTY	UNIT	TOTLE	TYPE	ASSY LEVEL
				WEIGHT			
		ITEM#: SHELF-ADJUSTABLE		MATERIAL:			
PROPRIETARY AND CONFIDENTIAL THE INFORMATION CONTAINED IN THIS DRAWING IS THE SOLE PROPERTY OF HARDWARE RESOURCES INC. ANY REPRODUCTION IN PART OR AS A WHOLE WITHOUT THE WRITTEN PERMISSION OF HARDWARE RESOURCES INC. IS PROHIBITED.		FINISH:		WEIGHT: 9		PROJECTION: 	
TOLERANCE UNLESS OTHERWISE SPECIFIED: X: MM ±0.20 X.X: MM ±0.10 X.XX: MM ±0.05 ANGULAR: ±0.5° DO NOT SCALE DRAWING		UNIT:	DRAWN BY: <i>alan.liu</i>	DATE:			
		SIZE:	CHECKED BY:	DATE:			
			APPROVED BY:	DATE:			

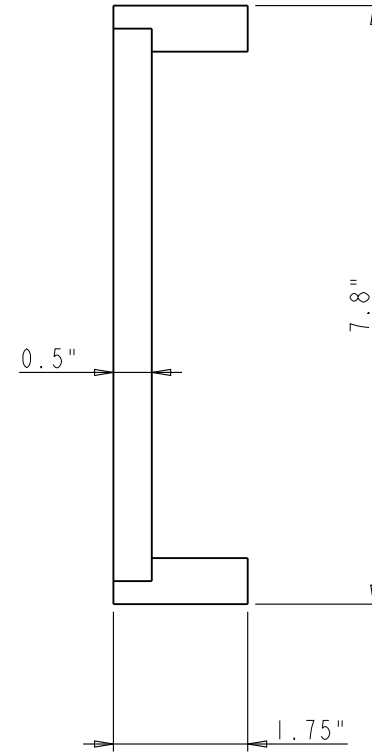
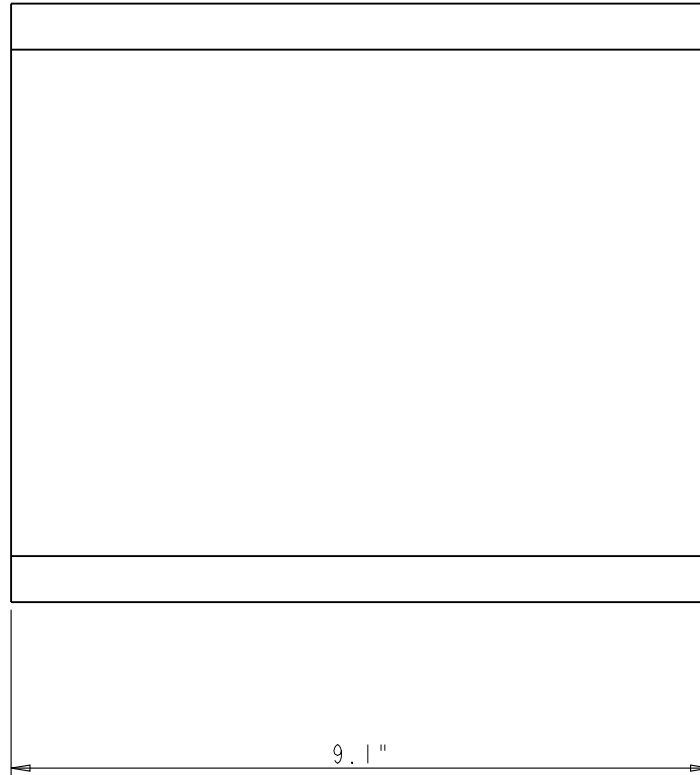

	ITEM#: SHELF - ADJUSTABLE - 8		MATERIAL:		
	FINISH:		WEIGHT: 9		
PROPRIETARY AND CONFIDENTIAL THE INFORMATION CONTAINED IN THIS DRAWING IS THE SOLE PROPERTY OF HARDWARE RESOURCES INC. ANY REPRODUCTION IN PART OR AS A WHOLE WITHOUT THE WRITTEN PERMISSION OF HARDWARE RESOURCES INC. IS PROHIBITED.	TOLERANCE UNLESS OTHERWISE SPECIFIED: X : MM ±0.20 X.X : MM ±0.10 X.XX : MM ±0.05 ANGULAR: ±0.5° DO NOT SCALE DRAWING		UNIT: SIZE:	DRAWN BY: <i>alan.liu</i>	DATE:
				CHECKED BY:	DATE:
				APPROVED BY:	DATE:

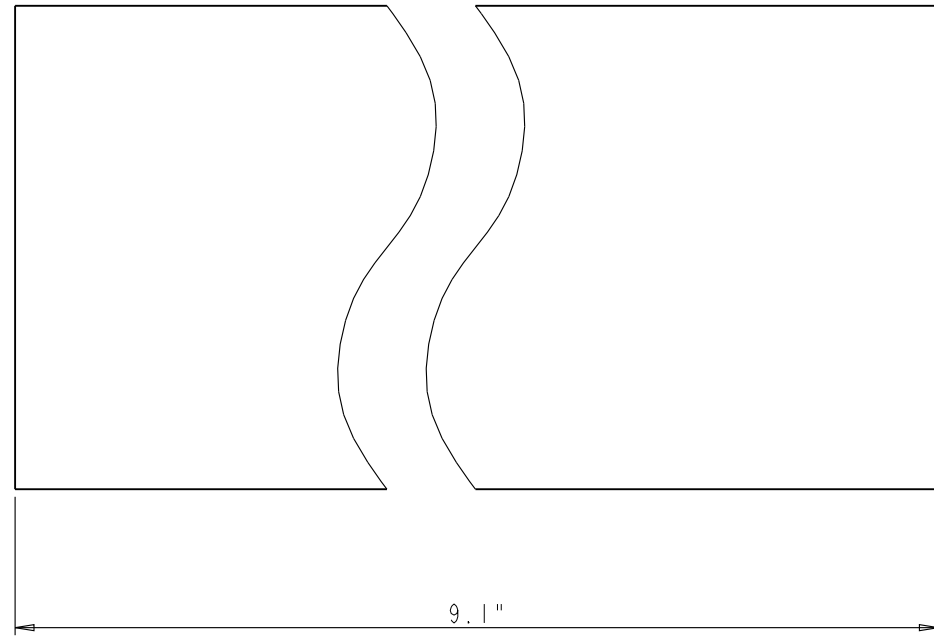
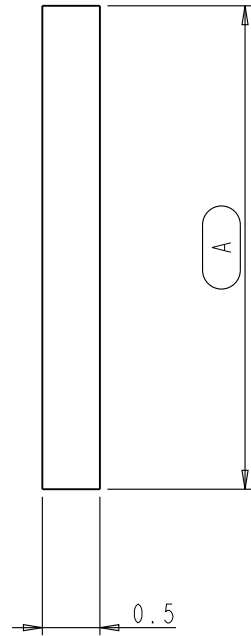

SHELF-BOARD-ADJUSTABLE SPEC SHEET:

Part Name	A
SHELF-BOARD-ADJUSTABLE-5"	4.2"
SHELF-BOARD-ADJUSTABLE-8"	7.2"

NOTE:

The dimension A of current SHELF-BOARD-ADJUSTABLE is showing with red frame

	ITEM#: SHELF-BOARD-ADJUSTABLE		MATERIAL: PLY Wood		
	FINISH:		WEIGHT: 9		
PROPRIETARY AND CONFIDENTIAL THE INFORMATION CONTAINED IN THIS DRAWING IS THE SOLE PROPERTY OF HARDWARE RESOURCES INC. ANY REPRODUCTION IN PART OR AS A WHOLE WITHOUT THE WRITTEN PERMISSION OF HARDWARE RESOURCES INC. IS PROHIBITED.	TOLERANCE UNLESS OTHERWISE SPECIFIED: X : MM ±0.20 X.X : MM ±0.10 X.XX : MM ±0.05 ANGULAR: ±0.5° DO NOT SCALE DRAWING		UNIT:	DRAWN BY: <i>alan.liu</i>	DATE:
	SIZE:	CHECKED BY:	DATE:		
	APPROVED BY:		DATE:		
	PROJECTION:				

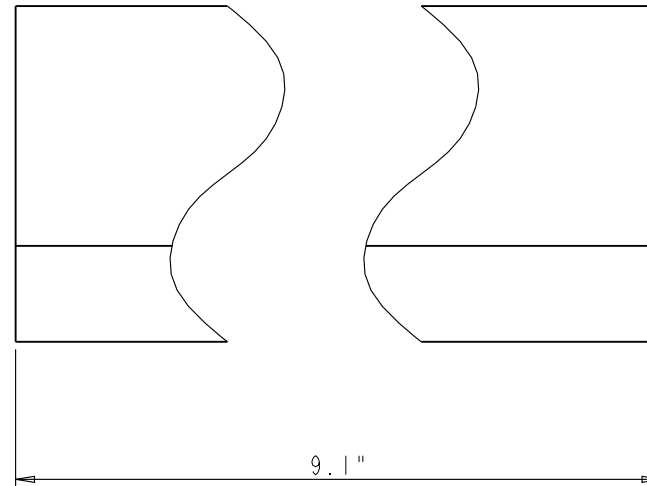
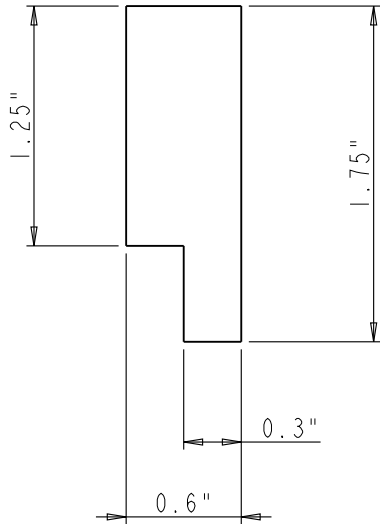

	ITEM: SIDE-BOARD-ADJUSTABLE-SHELF		MATERIAL: PLY Wood		
	FINISH:		WEIGHT: 9		
PROPRIETARY AND CONFIDENTIAL THE INFORMATION CONTAINED IN THIS DRAWING IS THE SOLE PROPERTY OF HARDWARE RESOURCES INC. ANY REPRODUCTION IN PART OR AS A WHOLE WITHOUT THE WRITTEN PERMISSION OF HARDWARE RESOURCES INC. IS PROHIBITED.	TOLERANCE UNLESS OTHERWISE SPECIFIED: X : MM ±0.20 X.X : MM ±0.10 X.XX : MM ±0.05 ANGULAR: ±0.5° DO NOT SCALE DRAWING		UNIT:	DRAWN BY: alan.liu	DATE:
	SIZE:	CHECKED BY:	DATE:	PROJECTION:	
	APPROVED BY:	DATE:			

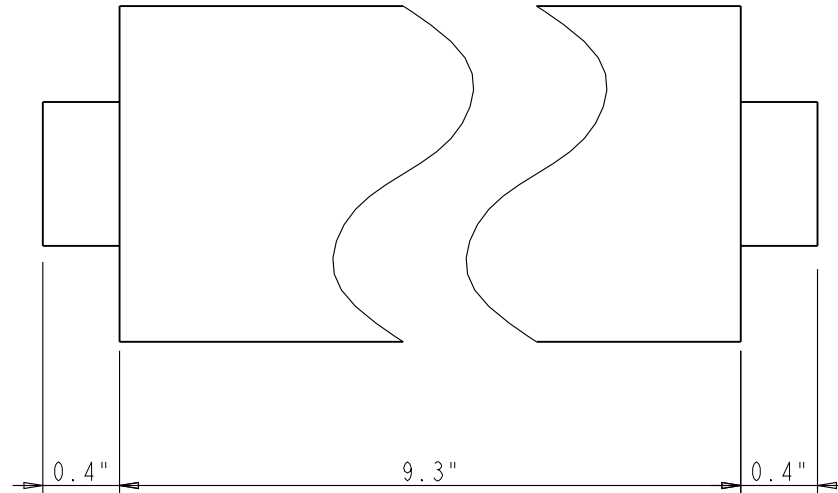
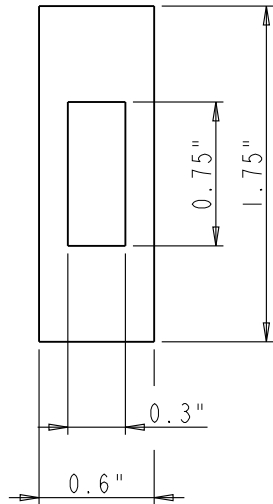

	ITEM: SIDE-BOARD-SUPPORT		MATERIAL: PLY Wood		
	FINISH:		WEIGHT: 9		
PROPRIETARY AND CONFIDENTIAL THE INFORMATION CONTAINED IN THIS DRAWING IS THE SOLE PROPERTY OF HARDWARE RESOURCES INC. ANY REPRODUCTION IN PART OR AS A WHOLE WITHOUT THE WRITTEN PERMISSION OF HARDWARE RESOURCES INC. IS PROHIBITED.	TOLERANCE UNLESS OTHERWISE SPECIFIED: X : MM ±0.20 X.X : MM ±0.10 X.XX : MM ±0.05 ANGULAR: ±0.5° DO NOT SCALE DRAWING		UNIT: SIZE:	DRAWN BY: <i>alan.liu</i>	DATE:
				CHECKED BY:	DATE:
				APPROVED BY:	DATE:

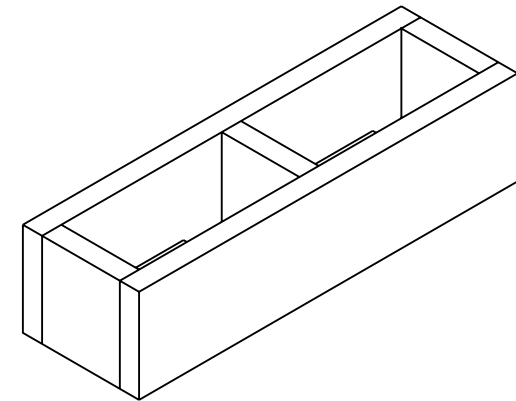
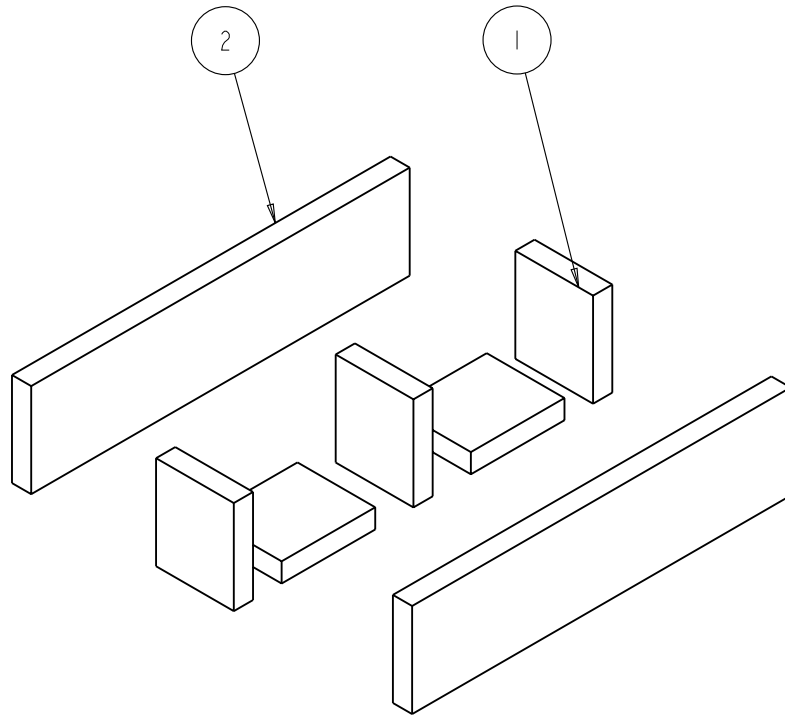

Bills of Material:

2	SLIDER-MOUNT-BOARD-PULLOUT	PLY Wood	2			PART	1
1	STRENGTHEN-BOARD	PLY Wood	5			PART	1
NO.	ITEM#	MATERIAL	QTY	UNIT	TOTLE	TYPE	ASSY LEVEL
				WEIGHT			
		ITEM#		MATERIAL:			
PROPRIETARY AND CONFIDENTIAL THE INFORMATION CONTAINED IN THIS DRAWING IS THE SOLE PROPERTY OF HARDWARE RESOURCES INC. ANY REPRODUCTION IN PART OR AS A WHOLE WITHOUT THE WRITTEN PERMISSION OF HARDWARE RESOURCES INC. IS PROHIBITED.		BOTTOM		WEIGHT:			
		FINISH:		9			
				PROJECTION:			
		TOLERANCE UNLESS OTHERWISE SPECIFIED: X : MM ±0.20 X.X : MM ±0.10 X.XX : MM ±0.05 ANGULAR: ±0.5° DO NOT SCALE DRAWING		UNIT:		DRAWN BY: <i>alan.liu</i>	
		SIZE:		CHECKED BY:		DATE:	
				APPROVED BY:		DATE:	

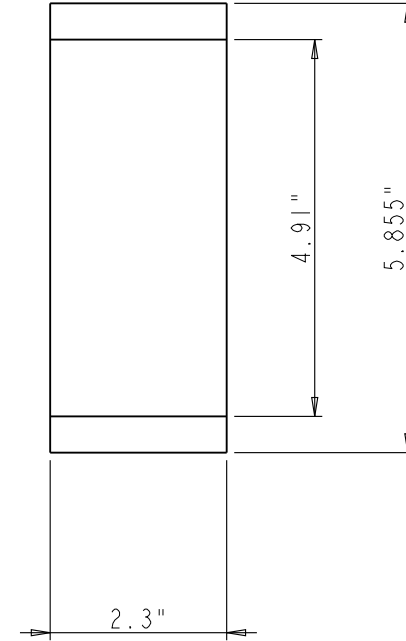
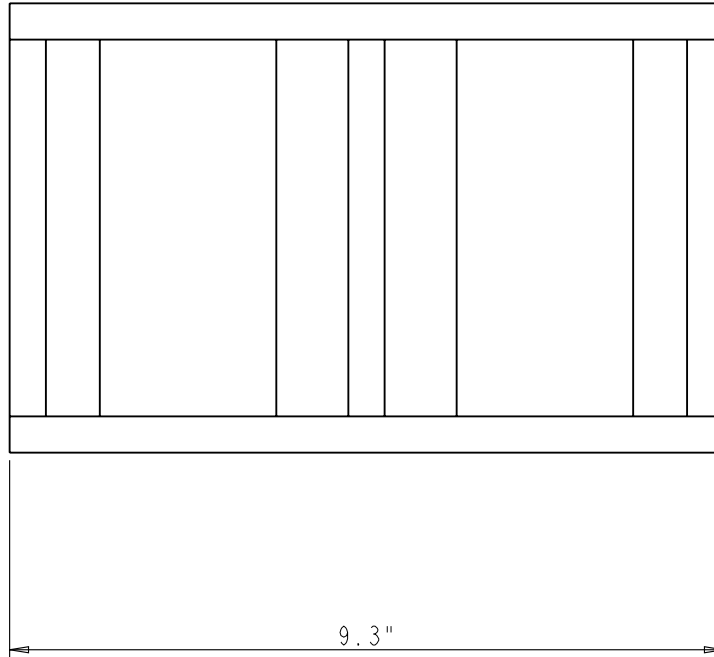

	ITEM: BOTTOM-8		MATERIAL:		
	FINISH:		WEIGHT: 9		
PROPRIETARY AND CONFIDENTIAL THE INFORMATION CONTAINED IN THIS DRAWING IS THE SOLE PROPERTY OF HARDWARE RESOURCES INC. ANY REPRODUCTION IN PART OR AS A WHOLE WITHOUT THE WRITTEN PERMISSION OF HARDWARE RESOURCES INC. IS PROHIBITED.	TOLERANCE UNLESS OTHERWISE SPECIFIED: X : MM ±0.20 X.X : MM ±0.10 X.XX : MM ±0.05 ANGULAR: ±0.5° DO NOT SCALE DRAWING		UNIT: SIZE:	DRAWN BY: <i>alan.liu</i>	DATE:
				CHECKED BY:	DATE:
				APPROVED BY:	DATE:

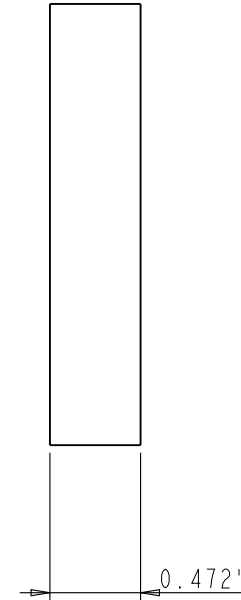
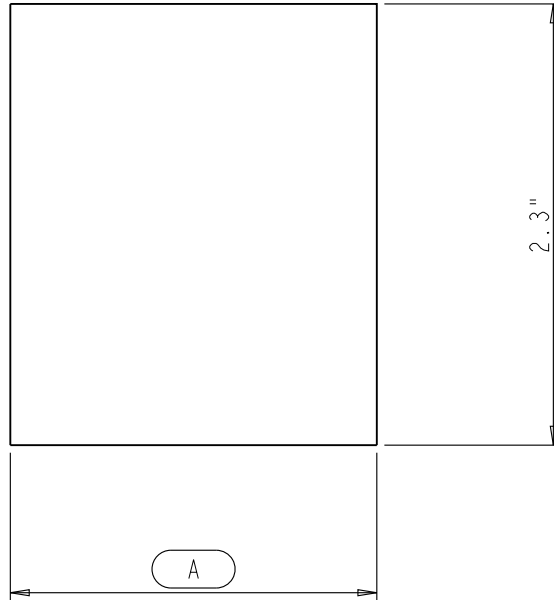

STRENGTHEN-BOARD SPEC SHEET:

Part Name	A
STRENGTHEN-BOARD-5"	1.91"
STRENGTHEN-BOARD-8"	4.91"

NOTE:

The dimension A of current STRENGTHEN-BOARD is showing with red frame

	ITEM#: STRENGTHEN-BOARD		MATERIAL: PLY Wood		
	FINISH:		WEIGHT: 9		
PROPRIETARY AND CONFIDENTIAL THE INFORMATION CONTAINED IN THIS DRAWING IS THE SOLE PROPERTY OF HARDWARE RESOURCES INC. ANY REPRODUCTION IN PART OR AS A WHOLE WITHOUT THE WRITTEN PERMISSION OF HARDWARE RESOURCES INC. IS PROHIBITED	TOLERANCE UNLESS OTHERWISE SPECIFIED: X : MM ±0.20 X.X : MM ±0.10 X.XX : MM ±0.05 ANGULAR: ±0.5° DO NOT SCALE DRAWING		UNIT:	DRAWN BY: <i>alan.liu</i>	DATE:
	SIZE:	CHECKED BY:	DATE:		
	APPROVED BY:		DATE:		
	PROJECTION:				

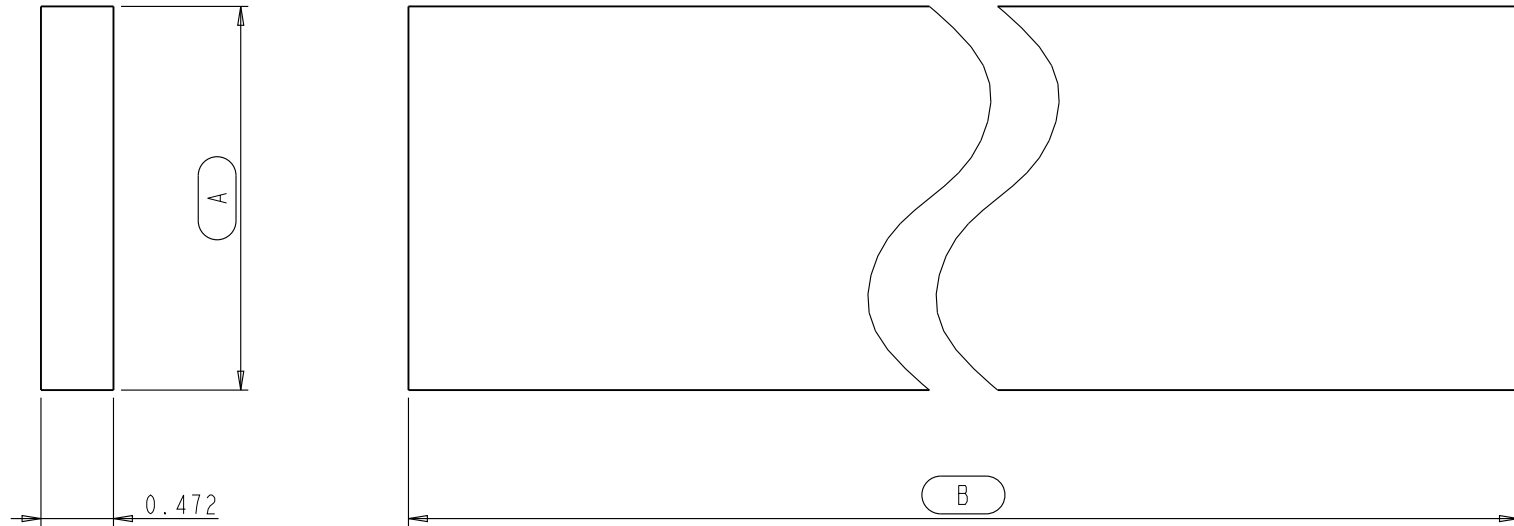

SLIDER-MOUNT-BOARD SPEC SHEET:

Part Name	A	B
SLIDER-MOUNT-BOARD-BASE	2.5"	9.899"
SLIDER-MOUNT-BOARD-PULLOUT	2.3"	9.3"

NOTE:

The dimension A & B of current SLIDER-MOUNT-BOARD is showing with red frame

	ITEM#: SLIDER-MOUNT-BOARD		MATERIAL: PLY Wood		
	FINISH:		WEIGHT: 9		
PROPRIETARY AND CONFIDENTIAL THE INFORMATION CONTAINED IN THIS DRAWING IS THE SOLE PROPERTY OF HARDWARE RESOURCES INC. ANY REPRODUCTION IN PART OR AS A WHOLE WITHOUT THE WRITTEN PERMISSION OF HARDWARE RESOURCES INC. IS PROHIBITED	TOLERANCE UNLESS OTHERWISE SPECIFIED: X : MM ±0.20 X.X : MM ±0.10 X.XX : MM ±0.05 ANGULAR: ±0.5° DO NOT SCALE DRAWING		UNIT:	DRAWN BY: <i>alan.liu</i>	DATE:
	SIZE:	CHECKED BY:	DATE:		
	APPROVED BY:		DATE:		
	PROJECTION:				

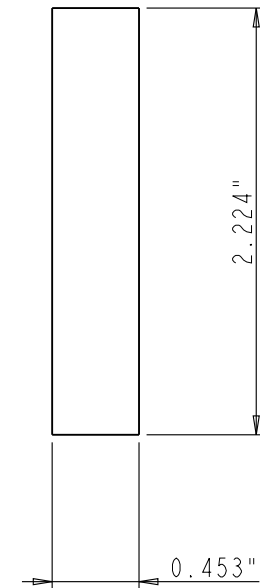

	ITEM#: HOLDER-MOUNT		MATERIAL: PLY Wood		
	FINISH:		WEIGHT: 9		
PROPRIETARY AND CONFIDENTIAL THE INFORMATION CONTAINED IN THIS DRAWING IS THE SOLE PROPERTY OF HARDWARE RESOURCES INC. ANY REPRODUCTION IN PART OR AS A WHOLE WITHOUT THE WRITTEN PERMISSION OF HARDWARE RESOURCES INC. IS PROHIBITED.	TOLERANCE UNLESS OTHERWISE SPECIFIED: X : MM ±0.20 X.X : MM ±0.10 X.XX : MM ±0.05 ANGULAR: ±0.5° DO NOT SCALE DRAWING		UNIT:	DRAWN BY: <i>alan.liu</i>	DATE:
	SIZE:	CHECKED BY:	DATE:		
	APPROVED BY:		DATE:		
	PROJECTION:				

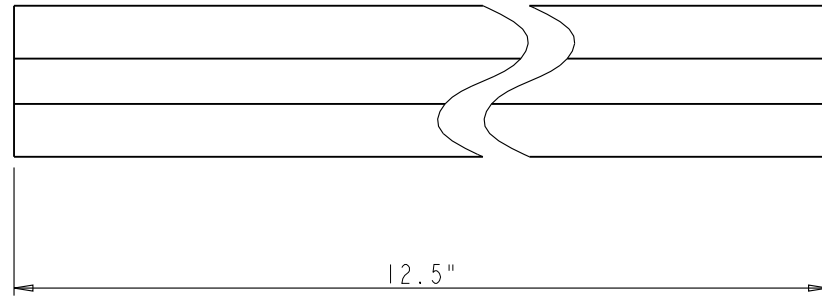
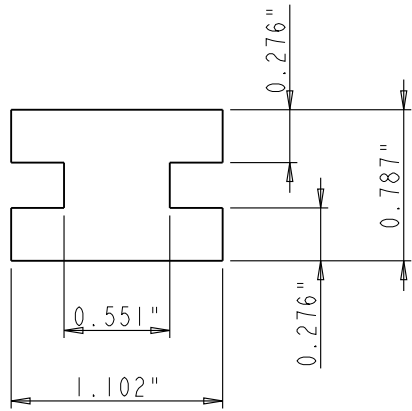

	ITEM#: RAIL		MATERIAL: RW		
	FINISH:		WEIGHT: 9		
PROPRIETARY AND CONFIDENTIAL THE INFORMATION CONTAINED IN THIS DRAWING IS THE SOLE PROPERTY OF HARDWARE RESOURCES INC. ANY REPRODUCTION IN PART OR AS A WHOLE WITHOUT THE WRITTEN PERMISSION OF HARDWARE RESOURCES INC. IS PROHIBITED.	TOLERANCE UNLESS OTHERWISE SPECIFIED: X : MM ±0.20 X.X : MM ±0.10 X.XX : MM ±0.05 ANGULAR: ±0.5° DO NOT SCALE DRAWING		UNIT:	DRAWN BY: <i>alan.liu</i>	DATE:
	SIZE:	CHECKED BY:	APPROVED BY:	DATE:	DATE:
	PROJECTION:				